

TM8100 mobiles
TM8200 mobiles

Installation Guide



MMA-00028-01
Issue 01
July 2005

Contact information

Tait Radio Communications Corporate Head Office

Tait Electronics Ltd
P.O. Box 1645
Christchurch
New Zealand

For the address and telephone number of regional offices, refer to the TaitWorld website:

Website: <http://www.taitworld.com>

Technical Support

For assistance with specific technical issues, contact Technical Support:

E-mail: support@taitworld.com

Website: <http://support.taitworld.com>



To our European customers:

Tait Electronics Limited is an environmentally responsible company which supports waste minimization and material recovery. The European Union's Waste Electrical and Electronic Equipment Directive requires that this product be disposed of separately from the general waste stream when its service life is over. Please be environmentally responsible and dispose through the original supplier, your local municipal waste "separate collection" service, or contact Tait Electronics Limited.

Contents

Preface	4
Scope of Manual	4
Enquiries and Comments	4
Updates of Manual and Equipment	4
Copyright	4
Disclaimer	4
Associated Documentation	5
Document Conventions	5
Safety Warnings	6
RF Exposure Hazard	6
Safe Radio Mounting	6
Interference with Vehicular Electronics	7
Preparation when Drilling Holes	7
Vehicles Powered by Liquefied Petroleum Gas	7
Radio Installation in Gas or Fuel tankers	7
Non-standard Radio Installations	8
Negative Earth Supply	8
1 Preparing the Installation	9
1.1 Regulations	9
1.2 Installation Tools	9
1.3 Checking the Equipment for Completeness	9
1.4 Choosing an Installation Configuration	11
2 Installing the Radio	12
2.1 Mounting and Removing the Control Head	12
2.2 Selecting the Mounting Position	14
2.3 Mounting the U-Bracket	15
2.4 Installing the Antenna	16
2.5 Connecting the Power Cable to the Power Source	17
2.6 Connecting a Remote Speaker	19
2.7 Connecting to the Auxiliary Connector (Ignition Signal, Emergency Switch, External Alert Devices)	19
2.8 Installing the Radio	23
2.9 Installing the Microphone	24
2.10 Checking the Installation	25
2.11 Blank Control Head	25
2.12 RJ45 Control Head	26
Tait General Software Licence Agreement	28

Preface

Scope of Manual

This manual describes the installation of the TM8100/TM8200 mobile radio using the U-bracket, and how to install and connect the microphone, antenna, emergency switch, and external alert device.

Other cradle mounting arrangements are available for the TM8100/TM8200 radio, but are not described in this manual.

The installation of accessories and mounting options is described in the installation instructions provided with the equipment, and the relevant section in the service manual.

Enquiries and Comments

If you have any enquiries regarding this manual, or any comments, suggestions or notifications of errors, please contact Technical Support, Tait Electronics Ltd, Christchurch, New Zealand (refer to [“Contact information”](#) on page 2).

Updates of Manual and Equipment

In the interests of improving the performance, reliability, or servicing of the equipment, Tait Electronics Ltd reserves the right to update the equipment or this manual or both without prior notice.

Copyright

All information contained in this manual is the property of Tait Electronics Ltd. All rights are reserved. This manual may not, in whole or in part, be copied, photocopied, reproduced, translated, stored, or reduced to any electronic medium or machine-readable form, without prior written permission from Tait Electronics Limited. All trade names referenced are the service mark, trademark or registered trademark of the respective manufacturers.

Disclaimer

There are no warranties extended or granted by this manual. Tait Electronics Ltd accepts no responsibility for damage arising from use of the information contained in the manual or of the equipment and software it describes. It is the responsibility of the user to ensure that use of such information, equipment and software complies with the laws, rules and regulations of the applicable jurisdictions.

Associated Documentation

TM8100 and TM8200 User's Guide.

TM8100/TM8200 Operator's Manual.

TM8100/TM8200 Service Manual.

Technical notes are published from time to time to describe applications for Tait products, to provide technical details not included in manuals, and to offer solutions for any problems that arise.

All available TM8100/TM8200 product documentation is provided on the CD supplied with the service kit¹. Updates may also be published on the Tait support website.

Document Conventions

Within this manual, four types of alerts are given to the reader: Warning, Caution, Important and Note. The following paragraphs illustrate each type of alert and its associated symbol.



Warning!! This alert is used when there is a potential risk of death or serious injury.



Caution This alert is used when there is the risk of minor or moderate injury to people.



Important This alert is used to warn about the risk of equipment damage or malfunction.



Note This alert is used to highlight information that is required to ensure procedures are performed correctly.

Within this manual, the following symbols are used to highlight differences between the 40 W/50 W and the 25 W radios:



This symbol highlights information that is relevant to 40 W/50 W radios.



This symbol highlights information that is relevant to 25 W radios.

1. Technical notes are only available in PDF format from the Tait support website. Consult your nearest Tait Dealer or Customer Service Organization for more information.

Safety Warnings

This section contains important information on the safe installation of the radio. You must read this information before starting the installation.

You must also read and observe the safety information on radio operation provided in the user's guide.

RF Exposure Hazard

To comply with FCC RF exposure limits:



For 40 W/50 W radios:

- VHF radios must be installed using an antenna mounted centrally on the vehicle roof, with a gain of 2.15 dBi or 5.15 dBi.
- UHF radios must be installed using an antenna mounted either centrally on the roof with a gain of 2.15 dBi or 5.65 dBi, or centrally mounted on the trunk with a gain of 5.65 dBi.



For 25 W radios:

- The radio must be installed using an externally mounted antenna with a gain of either 2.15 dBi or 5.15 dBi.

In all cases, the antenna must not be mounted at a location such that any person or persons can come closer than 35 inches (0.9m) to the antenna.

Safe Radio Mounting



Warning!! Mount the radio securely so that it will not break loose in the event of a collision. An unsecured radio is dangerous to the vehicle occupants.

- Mount the radio and the microphone where they will not interfere with:
 - the deployment of passenger airbags
 - the vehicle operator controls
 - the vehicle operator's view.
- Do not mount the radio vertically, with the control head facing down. This will violate compliance with the standards UL/CSA/EN 60950, Safety of Information Technology Equipment.

Interference with Vehicular Electronics



Warning!! Some vehicular electronic devices may be prone to malfunction due to the lack of protection from RF energy when your radio is transmitting.

Examples of vehicular electronic devices that may be affected by RF energy are:

- electronic fuel injection systems
- electronic anti-skid braking systems
- electronic cruise control systems
- indicators.

If the vehicle contains such equipment, consult the vehicle manufacturer or dealer to determine whether these electronic circuits will perform normally when the radio is transmitting.

Preparation when Drilling Holes



Warning!! When drilling holes in the vehicle, check that drilling at the selected points will not damage existing wiring, petrol tanks, fuel lines, brake pipes, or battery cables.

Vehicles Powered by Liquefied Petroleum Gas



Warning!! Radio installation in vehicles powered by LPG (liquefied petroleum gas) with the LPG container in a sealed-off space within the interior of the vehicle must conform to the National Fire Protection Association Standard NFPA 58. This standard states that the radio equipment installation must meet the following requirements:

- The space containing the radio equipment shall be isolated by a seal from the space containing the LPG container and its fitting.
- Outside filling connections shall be used for the LPG container and its fittings.
- The LPG container space shall be vented to the outside of the vehicle.

Radio Installation in Gas or Fuel tankers

Special conditions must be observed when installing a radio on gas and fuel tankers. Consult your radio provider or Tait-accredited service center for more details.

Non-standard Radio Installations

The installation U-bracket described in this guide has been designed so that there is enough airflow around the radio to provide cooling.

If a non-standard installation method is used, care must be taken that sufficient heat can be dissipated from the heatsink fins and the ridged bottom surface of the radio.

For this to be achieved, there must be a gap of more than 3/8 inch (10 mm) between the bottom surface of the radio chassis and the mounting surface. This is illustrated in the following diagram (TM8200 radio shown):

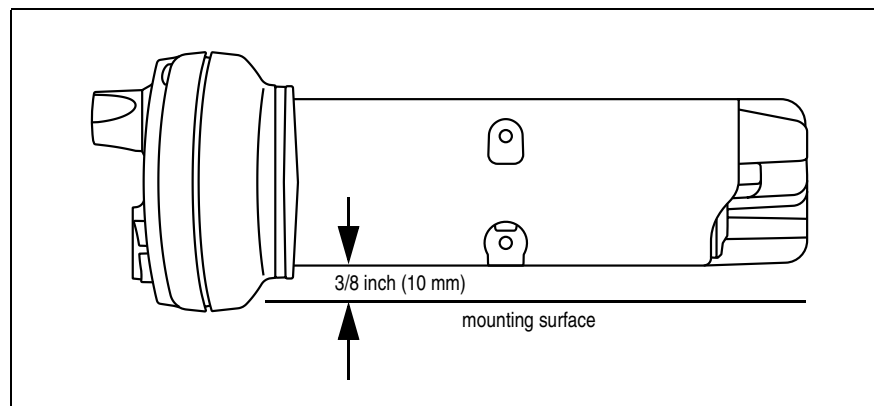

Negative Earth Supply

The radios are designed to operate only in a negative earth system.

1 Preparing the Installation

This section contains the following information:

- regulations
- installation tools
- checking the equipment for completeness
- choosing an installation configuration.

1.1 Regulations

MPT 1362 Code of Practice

TM8100/TM8200 mobile radios should be installed in accordance with the MPT 1362 Code of Practice. This code of practice covers the installation of mobile radio equipment in land based vehicles and has been developed by the United Kingdom Office of Communication (Ofcom). For the full text of the MPT 1362 Code of Practice, go to the Ofcom website: http://www.ofcom.org.uk/codes_guidelines/radio_comms/radio equip_stnds/.

Vehicle Manufacturer's Installation Instructions

Follow your vehicle manufacturer's instructions for installing mobile radios. For more information, refer to the vehicle manufacturer's website or contact the vehicle manufacturer's dealer.

1.2 Installation Tools

The following tools are required to install of the radio:

- drill and drill bits
- Pozidriv screwdriver
- 5/16 inch (8 mm) socket
- R/F connector crimp tool
- fuse crimp tool
- in-line RF power meter capable of measuring forward and reflected power at the operating frequency of the radio.

1.3 Checking the Equipment for Completeness

Unpack the radio and check that you have the following:

1. A radio body with one of the following product codes:

TM8100:

- TMAB14 radio body (40 W/50 W radio), or
TMAB12 radio body (25 W radio)

TM8200:

- TMAB24 radio body (40 W/50 W radio), or
TMAB22 radio body (25 W radio).



2. A control head, including control-head loom, with one of the following product codes:
 - TM8100:**
 - TMAC10 control head (TM8105 radio),
TMAC20 control head (TM8115 radio), or
TMAC50 control head (TM8110 radio).
 - TM8200:**
 - TMAC30 control head (TM8252 radio), or
TMAC40 control head (TM8250 or TM8255 radio).
3. TMAA02-01 microphone or TMAA02-08 keypad microphone, including microphone clip and screws (not required for the TM8105 or TM8252 radio)

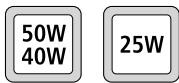

4. A TMAA03-17 installation kit (40 W/50 W radio), or TMAA03-01 installation kit (25 W radio), consisting of the following items:
 - U-bracket
 - thumbscrews
 - self-drilling screws and washers
 - power cable with DC connector
 - fuses
 - in-line fuse holders
 - receptacles for a remote speaker (remote speaker not included)
 - antenna connector.

Refer to the following section, [“Installation Kit Options”](#).



Warning!! Danger of fire. The radio’s protection mechanisms rely on the correct fuses on both the negative and positive power supply leads being present. Failure to fit the correct fuses may result in fire or damage to the radio. The correct fuse types are:

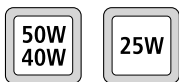

- **40 W/50 W radios: 20 A fuses (Tait IPN 365-00010-81)**
- **25 W radios: 10 A fuses (Tait IPN 365-00010-80).**

Installation Kit Options

Installation kits are also available without the U-bracket included and with other antenna connector options. Other cradle mounting arrangements are also available. Consult your nearest Tait Dealer or Customer Service Organization for more information.

1.4 Choosing an Installation Configuration

The radio allows for different installation configurations for vehicles with respect to ignition signal and standby current. For special configurations for desktop and remote site installations, refer to the service manual.

The installation configurations described below are based on the following hardware link configuration:

- hardware link 1 (+13.8V battery power sense): fitted
- hardware link 2 (ignition sense): fitted

For more information on the hardware links, refer to the service manual.

Direct Connection to the Power Source

The radio's power cable must always be connected directly to the power source (battery).



Important

Although it is possible to connect the radio in line with the vehicle ignition, this is not recommended, as it may draw too much current and damage the vehicle wiring and steering column or ignition switch. This may also cause the supply voltage of the radio to drop below the specified level.

The radio can always be turned on and off using the on/off button, independent of the ignition signal.

Installation without Ignition Signal

Connect the power cable directly to the power source as described in [“Connecting the Power Cable to the Power Source” on page 17](#).



Note

If hardware link 1 is fitted (factory default) and the ignition signal is not used, the standby current is approximately 50mA. To reduce the standby current to <3mA either:

- remove hardware link 1, or
- connect pin 4 (AUX GPI3) to pin 15 (AGND) of the auxiliary connector.



Note

With the above two options, the radio always stays off when power is first applied. The radio can only be turned on with the on/off button.

Installation with Ignition Signal

Connect the power cable directly to the power source as described in [“Connecting the Power Cable to the Power Source” on page 17](#).

Connect pin 4 (AUX GPI3) of the auxiliary connector to the ignition signal as described in [“Connecting to the Auxiliary Connector \(Ignition Signal, Emergency Switch, External Alert Devices\)” on page 19](#).

The AUX GPI3 line must be programmed to ‘Power Sense (Ignition)’ and active to ‘High’. For more information, refer to the online help of the programming application.



Note

The TMAA04-05 ignition sense kit provides a suitable mating plug for the radio's auxiliary connector. The plug includes wiring for the the ignition signal and analog ground.

2 Installing the Radio

This section contains the following information:

- mounting and removing the control head
- selecting the mounting position
- mounting the U-bracket
- installing the antenna
- connecting the power cable to the power source
- connecting a remote speaker
- connecting to the auxiliary connector (ignition signal, emergency switch, external alert devices)
- installing the radio
- installing the microphone
- checking the installation
- blank control head
- RJ45 control head.

2.1 Mounting and Removing the Control Head



Important

The control head contains devices which can be damaged by static discharges. Always install or remove the control head in a static-safe environment. For information on antistatic precautions, go to the Electrostatic Discharge Association (ESD) website, <http://www.esda.org>.

Mounting the Control Head

The control head and its connection loom are delivered separately from the radio body. Before installing the radio, the control head should be mounted on the radio body.

The orientation of the radio body determines which way up the control head is mounted on the radio body.



Note

It may be required to mount the radio upside down to maintain a gap of more than 3/8 inch (10 mm) for air circulation between the underside of the radio body and the mounting surface.

Figure 2.1 Mounting the control head

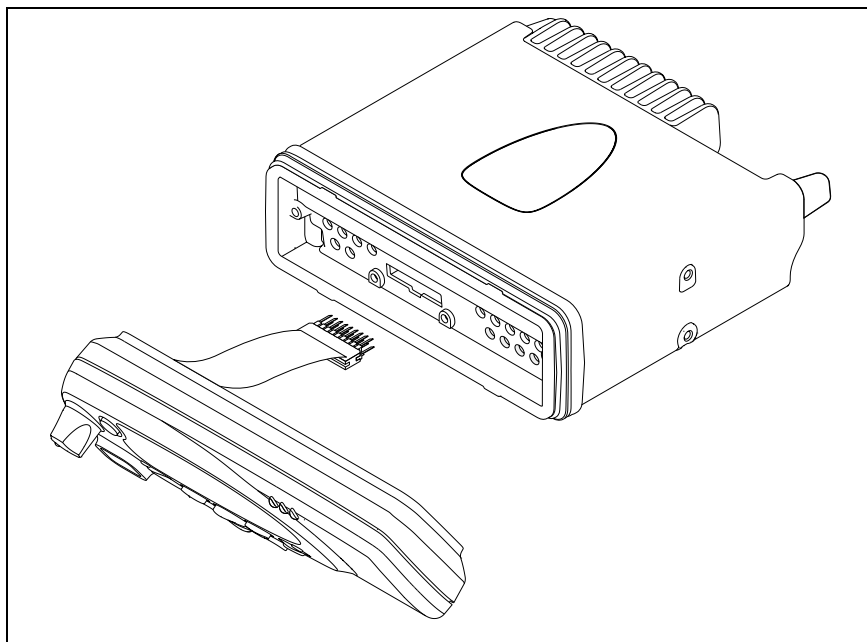

1. Plug the control-head loom onto the control-head connector.
2. Insert the bottom edge of the control head onto the two clips in the front of the radio body, then snap into place.

Removing the Control Head



Important

During this procedure, take care that the control-head seal is not damaged. Damage to this seal reduces environmental protection.

Figure 2.2 Removing the control head

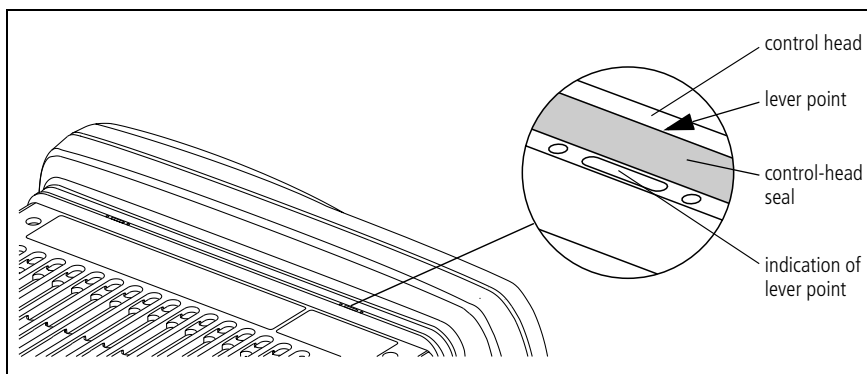

On the underside of the radio, two lever points are indicated on the radio body by a dot-dash-dot pattern (○ — ○). The lever point is between the control-head seal and the control head.

1. At either of the lever points, insert a 3/16 inch (5 mm) flat-bladed screwdriver between the control head and the control-head seal.
2. Use the screwdriver to lift the control head off the chassis clip, then repeat in the other position. The control head can now be removed from the radio body.

2.2 Selecting the Mounting Position

Requirements for Safe and Convenient Installation



Ensure the mounting position complies with the following safety warnings:

Warning!! Safe radio mounting

- Mount the radio securely so that it will not break loose in the event of a collision. An unsecured radio is dangerous to the vehicle occupants.
- Mount the radio and the microphone where they will not interfere with:
 - the deployment of passenger airbags
 - the vehicle operator controls
 - the vehicle operator's view.

Gap Between Radio Body and Mounting Surface



Note It may be necessary to mount the radio upside down to maintain a gap of more than 3/8 inch (10 mm) between the bottom surface of the radio body and the mounting surface.

Inspect the vehicle and determine the safest and most convenient position for mounting the radio. Make sure that there is sufficient clearance behind the radio for the heatsink and cables.

IP54 Protection Class Considerations



The radio fulfils the requirements of the IP54 protection class.

Important However, do not mount the radio in areas where it can be temporarily submerged from an accumulation of water or other liquids (e.g. when using a high-pressure cleaning device).

The IP54 protection class does not apply when:

- the control head is removed from the radio body
- the bungs are removed from the auxiliary connector or the cavity for the external options connector (fitting an auxiliary connector or external options connector will not restore the IP54 protection class)
- the programming connector cover seal is not installed (blank control head)
- the RJ45 connector bungs are not installed (RJ45 control head)
- the microphone grommet is not installed.

2.3 Mounting the U-Bracket

The U-bracket can be used to install the radio on the dashboard or on any sufficiently flat surface (e.g. cabin floor or trunk). The U-bracket can be mounted using the self-drilling screws and washers provided in the installation kit, or nuts and bolts (not included).



Caution Although an industrial-strength recloseable fastening system can be used to support the installation, for safety reasons Tait does not recommend this as a mounting option.



Important When mounting the radio on a surface, check whether the mounting screws will screw into material providing sufficient strength. Reinforce the mounting surface, if required.

1. If the U-bracket is being mounted over a curved surface, bend the tabs at the bottom of the U-bracket slightly to match the surface shape.
2. Hold the U-bracket in the position chosen for the radio and use the mounting holes as a template to mark the mounting locations. Use at least four screws to install the U-bracket.



Tip The screws provided are self-drilling. For more precise positioning, predrill $\text{Ø}1/8$ inch (3 mm) pilot holes for self-drilling screws. Reduce the hole size in metal that is less than $1/32$ inch (1 mm) thick.



Important Ensure that drilling at the selected points will not damage existing wiring.

3. Drill any holes required for cables and install suitable grommets or bushings in the holes.
4. Screw the U-bracket in the chosen mounting position using the self-drilling screws and washers provided. When tightening the screws, ensure that this does not distort the U-bracket.

Figure 2.3 Mounting the U-bracket

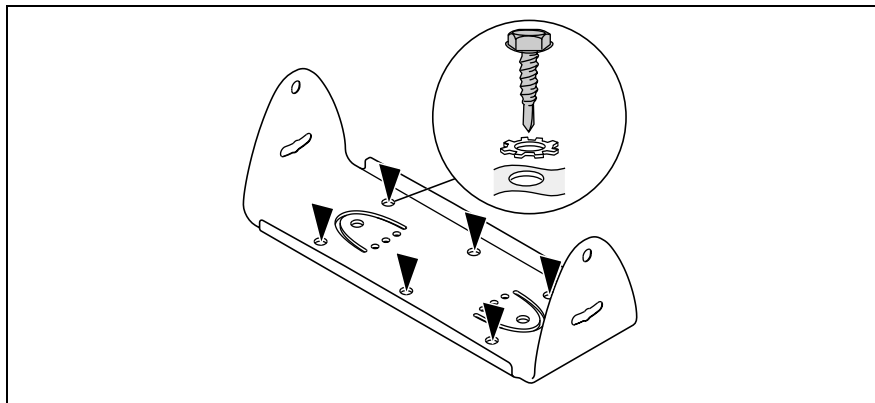

2.4 Installing the Antenna

This section provides information on installing an external antenna within the RF exposure limits.

Install the external antenna according to the antenna manufacturer's instructions. Good quality 50 Ω coaxial cable must be used, such as RG58 or UR76.



Important

Route the cable in a manner that minimizes:

- coupling into the electronic control systems of the vehicle
- coupling of electric vehicle systems, such as alternators, into the radio.

Avoid sharp bends in the cable. These distort the cable and alter its electrical characteristics.



Warning!! RF exposure hazard

To comply with FCC RF exposure limits:

1. Mount the antenna at a location such that no person or persons can come closer than 35 inches (0.9m) to the antenna.
2. For 40W/50W radios:
 - VHF radios must be installed using an antenna mounted centrally on the vehicle roof, with a gain of 2.15 dBi or 5.15 dBi.
 - UHF radios must be installed using an antenna mounted either centrally on the roof with a gain of 2.15 dBi or 5.65 dBi, or centrally mounted on the trunk with a gain of 5.65 dBi.
3. For 25W radios, the radio must be installed using an externally mounted antenna with a gain of either 2.15 dBi or 5.15 dBi.



Terminating the Antenna Cable

1. Run the free end of the coaxial cable to the radio's mounting position and cut it to length, allowing approximately 8 inches (20 cm) excess at the radio end.
2. Terminate the free end of the antenna cable with the mini-UHF plug or BNC plug (supplied) as shown in [Figure 2.4](#).

Figure 2.4 Terminating the antenna cable

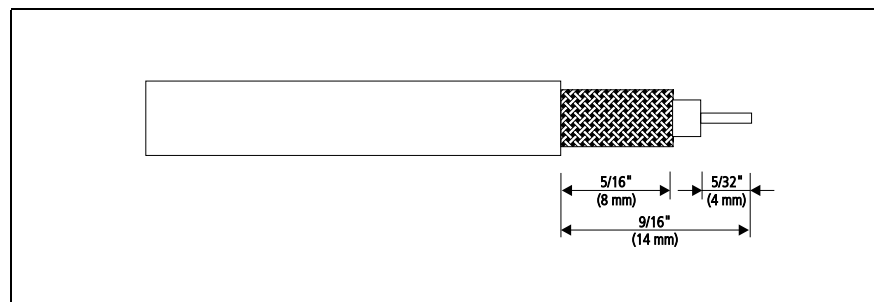

2.5 Connecting the Power Cable to the Power Source

This section provides information on connecting the power cable to the power source.

Power Connector

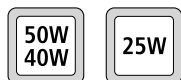

The power connector is the interface to the vehicle battery and an optional external remote speaker. Connecting a remote speaker is described in “[Connecting a Remote Speaker](#)” on page 19.

Table 2.1 Power connector (radio)—pins and signals

Pinout	Pin	Signal name	Description	Signal type
<p>40W/50W radio</p> <p>rear view</p> <p>25W radio</p> <p>rear view</p>	1	AGND	Earth return for radio body power source	Ground
	2	SPK-	External speaker output. Balanced load configuration	Analog
	3	SPK+	External speaker output. Balanced load configuration	Analog
	4	13V8 BATT	DC power input for radio body and control head	Power



Important

This radio is designed to operate from a nominal 12V negative ground supply and may draw up to 15 A of current. The radio will tolerate a supply voltage range of 10.8V to 16.0V at the radio.

Selecting the Power Source

In passenger vehicles, the radio is always connected directly to the battery using the power cable provided.

In trucks, where direct connection to the battery is often not possible, the radio can be connected to a suitable terminal inside the fuse box that is connected directly to the battery.

24V-to-12V Converter

In vehicles with a supply voltage larger than 16.0V, such as many trucks, it is essential to provide a suitably rated 24V-to-12V converter. This will isolate the radio from excessive battery voltage and provide the correct DC operating conditions. Note that most 24V-to-12V converters already fitted are not rated sufficiently.

Standby Current

When connecting the radio to the battery without using the ignition signal as described [on page 21](#), the standby current is approximately 50mA.

When using the ignition signal to turn off the radio, the standby current is reduced to <3mA.



Tip

To reduce the standby current from 50mA to <3 mA without using the ignition signal, connect pin 4 (AUX GPI3) and pin 15 (GND) of the auxiliary connector.

Connecting the Power Cable



Important Although it is possible to connect the radio in line with the vehicle ignition, this is not recommended, as it may draw too much current and damage the vehicle wiring and steering column or ignition switch. This may also cause the supply voltage of the radio to drop below the specified level.



Important Disconnecting the vehicle's battery may cause problems with some electronic equipment, such as vehicle alarms, engine management systems, and in-car entertainment systems. Check that the vehicle owner has the necessary information to make all electronic equipment function correctly after battery reconnection.



Important If the battery is not disconnected, exercise extreme caution during the installation and install the fuses only when the installation is ready to be checked. For more information, refer to [“Checking the Installation” on page 25](#).

1. Disconnect the vehicle's battery unless specifically prohibited from doing so by the customer, vehicle manufacturer, agent, or supplier.



Important Route the cable in a manner that minimizes coupling of electric vehicle systems such as alternators into the radio.



Important Protect the power cable from engine heat, sharp edges and from being pinched or crushed.

2. Run the power cable between the radio's mounting position and the power source and cut it to length, allowing approximately 8 inches (20 cm) excess at the radio end.
3. Plug the power cable into the power connector of the radio.
4. Cut the negative and the positive wires where the in-line fuse holders will be placed (as close to the power source as possible).



Important Do not install the fuses until the installation is ready to be checked. For more information, refer to [“Checking the Installation” on page 25](#).

5. Insert each end of the negative wire into each of the fuse crimp-terminals and crimp them to force the metal contacts onto the wires.
6. Push the two crimp-terminals into the clear plastic fuse cover. Close the cover while the next steps are completed.
7. Repeat steps 5 and 6 for the positive wire.
8. Connect the negative wire to the battery ground terminal
9. Connect the positive wire to the battery positive terminal.



Important Do not install the fuses until the installation is ready to be checked. For more information, refer to [“Checking the Installation” on page 25](#).

2.6 Connecting a Remote Speaker

If a high-power remote speaker is required, Tait recommends using:

- TMAA10-06 high-power remote speaker for 40 W/50 W radios
- TMAA10-03 high-power remote speaker for 25 W radios.

If a different speaker is used, receptacles for the speaker pins of the power connector are provided with the installation kit.

Connect the speaker to pins 2 (SPK-) and 3 (SPK+) of the power connector described [on page 17](#).

For more information, refer to the installation instructions provided with the speaker, or to the relevant section of the service manual.

2.7 Connecting to the Auxiliary Connector (Ignition Signal, Emergency Switch, External Alert Devices)

The auxiliary connector can be used to connect external devices and signals that are typically connected to a radio. These devices and signals include:

- the ignition signal to power up and power down the radio
- an emergency switch to power up the radio (if required) and then enter emergency mode
- external alert devices.

Auxiliary Connector

The radio's auxiliary connector is a 15-way standard-density D-range socket.



Note The space for a mating plug is limited to 1 5/8 inch (41 mm) in width and 1 1/4 inch (18 mm) in height. It is recommended that you test the plug to be used before manufacturing a cable. Tait uses IPN 240-00020-55 for the plug.

Table 2.2 Auxiliary connector (radio)—pins and signals

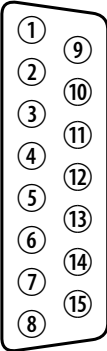
Pinout	Pin	Signal name	Description	Signal type	
 <p>rear view</p>	12	AUX GPI1	General purpose digital input. Programmable function	Digital, 3V3 CMOS.	
	5	AUX GPI2			
	4	AUX GPI3	General purpose input (ignition sense)	3V3 levels. Protected for +13.8V.	
	10	AUX GPIO4	Programmable function and direction	Digital, 3V3 CMOS input; open collector output with pullup	
	2	AUX GPIO5	Pads available to fit a higher power driver transistor on GPIO4 line		
	9	AUX GPIO6			
	1	AUX GPIO7			
	11	AUX TXD	Asynchronous serial port - Transmit data	Digital, 3V3 CMOS	
	3	AUX RXD	Asynchronous serial port - Receive data	Digital, 3V3 CMOS	
	7	AUD TAP IN	Programmable tap point into the Rx or Tx audio chain. DC-coupled	Analog	
	13	AUD TAP OUT	Programmable tap point out of the Rx or Tx audio chain. DC-coupled	Analog	
	14	AUX MIC AUD	Auxiliary microphone input. Electret microphone biasing provided. Dynamic microphones are not supported	Analog	
	6	RSSI	Analog RSSI output	Analog	
	8	+13V8 SW	Switched 13.8V supply. Supply is switched off when radio body is switched off	Power	
	15	AGND	Analog ground	Ground	

Shielding

If the auxiliary cable is longer than 4 feet (1 m) it is recommended that the cable and connector backshell are shielded. Figure 2.5 shows the recommended shielding arrangement. The earth braid wire (bare copper) and aluminum foil should only be earthed at the radio end of the cable.

Figure 2.5 Auxiliary cable and connector shielding

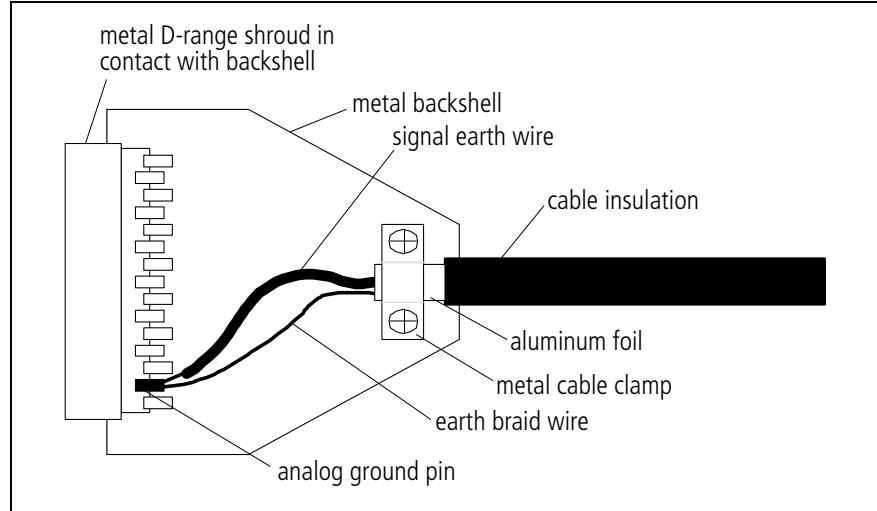

Ignition Signal

The ignition signal can be used to power up and power down the radio. This will turn the radio off when the ignition key is off to avoid flattening the battery, and will turn the radio on or return to its previous state (as programmed) when the ignition key is on.



Note A TMAA04-05 ignition sense kit is available. The kit comprises a mating plug for the radio's auxiliary connector and a 13 foot (four metre) length of cable to connect to the vehicle's ignition signal.



Note The AUX GPI3 line **must** be programmed to 'Power Sense (Ignition)' and active to 'High'. For more information, refer to the online help of the programming application.

Connect the ignition signal to pin 4 (AUX GPI3) of the auxiliary connector.



Note The logic thresholds for AUX GPI3 are based on 3V3 levels. However, AUX GPI3 can be connected directly to a +13.8V ignition signal.

Emergency Switch

The radio allows for connection of an emergency switch to any input line to enter the emergency mode. If connected to the AUX GPI2 input line, the radio can also use 'emergency power sense' to power up the radio to enter the emergency mode.



Note The selected input line must be programmed to 'Enter Emergency Mode' and active to 'Low'. To use 'emergency power sense', hardware link LK3 must be fitted (factory default), and AUX GPI2

must be used. For more information, refer to the service manual and the online help of the programming application.

Connect a normally open switch between the pin of the input line (pin 5 for AUX GPIO2) and pin 15 (AGND) of the auxiliary connector.

External Alert Device The radio allows for output to external alert devices using the digital GPIO lines of the auxiliary connector and the internal options connector.

AUX GPIO4 can be fitted with a power MOSFET (Q707) to directly connect external alert devices (e.g. flashing light, buzzer, horn relay) to the radio. Also, resistor R768 must be removed.



Important While the MOSFET is rated at 12 A (with heat sink), the maximum allowable current of the connector and radio's earthing system is 2 A. Therefore, a horn must not be connected directly to the radio. A horn relay must be used.



Note The selected output line must be programmed to 'External Alert 1 or 2', active to 'Low', and signal state to 'Momentary'.

Connect the external alert device to the pin of the output line (pin 10 for AUX GPIO4) and pin 8 (+13V8 SW) of the auxiliary connector (or a different positive battery connection).

This means that the negative side of the alert device must be connected to AUX GPIO4 and the positive side to pin 8 (+13V8 SW). The external alert device must be capable of accepting a voltage of between 10V and 18V.

2.8 Installing the Radio

1. Connect the antenna cable, power cable, and—if applicable—the auxiliary cable to the rear of the radio.
2. Position the radio in the U-bracket so that the holes in the U-bracket line up with the holes in the radio chassis.
3. Screw the radio into position using the four thumb screws provided, but without fully tightening the screws.
4. Adjust the position of the radio in the U-bracket for the best viewing angle, then tighten the thumb screws.

Figure 2.6 Installing the radio in the U-bracket

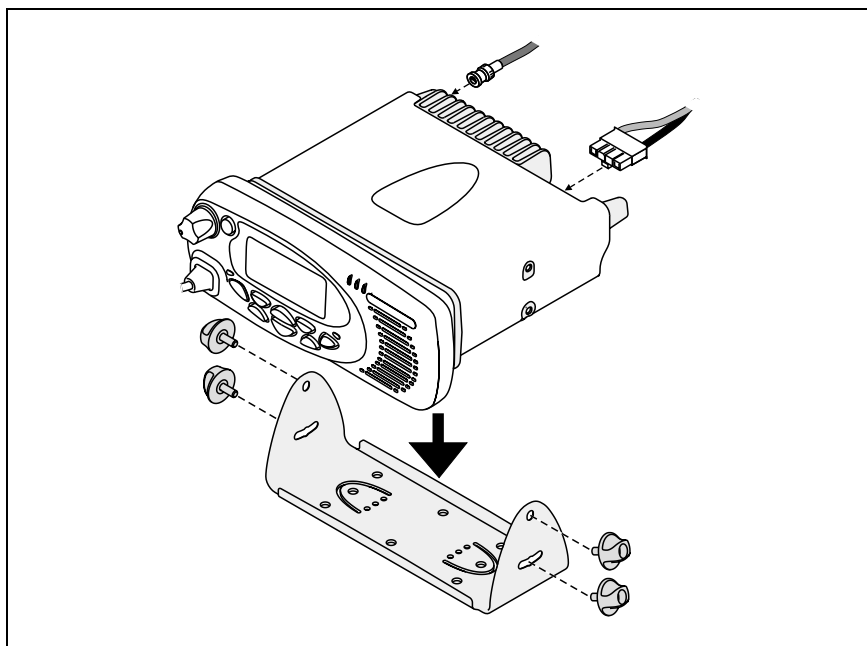

2.9 Installing the Microphone

This section describes the radio's microphone connector and the information required to connect the microphone and install the microphone clip.



- Important** The microphone grommet must be installed whenever the microphone is plugged into the microphone socket:
- to prevent damage to the microphone socket when there is movement of the microphone cord, and
 - to ensure that the control head is sealed against water, dust and other environmental hazards.

Connecting the Microphone

1. Plug the microphone into the microphone socket.
2. Slide the grommet along the microphone cord and push two adjacent corners of the grommet into the microphone socket cavity.
3. Squeeze the grommet and push the remaining corners into position.
4. Check that the grommet is seated correctly in the cavity.

Installing the

Figure 2.7 Correct remote cable grommet seating

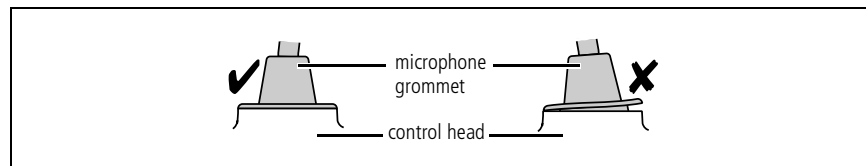

Microphone Clip



Warning!! Safe radio mounting

- Mount the microphone where it will not interfere with:
 - the deployment of passenger airbags
 - the vehicle operator controls
 - the vehicle operator's view.



- Important** Only install the microphone clip provided. If a non-standard microphone clip is used, the correct operation of the microphone hookswitch cannot be guaranteed.

Install the microphone clip in the most convenient location using the screws provided. The microphone must be within reach of the user but in such a position that the PTT (press-to-talk) key cannot be inadvertently activated or jammed.

2.10 Checking the Installation



Warning!! Danger of fire. The radio's protection mechanisms rely on the correct fuses on both the negative and positive power supply leads being present. Failure to fit the correct fuses may result in fire or damage to the radio. The 40 W/50 W radios use 20A fuses; the 25 W radios use 10A fuses. For part numbers of the fuses, refer to [“Checking the Equipment for Completeness” on page 9](#).



1. Insert the fuses into the power leads.
2. Switch on the radio to confirm that it is operational, but do not transmit.
3. Connect an in-line power meter between the radio and the antenna.
4. Transmit and measure the forward and reflected power levels. Less than 4% of the forward power should be reflected. If this is not achieved, check the installation, including the antenna length.
5. Start reducing the length of the antenna in steps of 0.1 inches to 0.2 inches (2 to 5 mm). Measure the power levels at each step.



Important Some antennas are pre-tuned and must not be cut. Check with the manufacturers' instructions.

6. Once the reflected power levels are within tolerance, make a call to another party on the radio.

2.11 Blank Control Head

The blank control head on the TM8105 radio has a 9-way D-range plug on the control head, for programming.



Important When the programming connector is not in use, the connector seal must be installed. This ensures that the control head is sealed against water, dust and other environmental hazards.

Figure 2.8 TM8105 radio with the blank control head



Pin allocations for the blank control head

The pin allocations for the programming connector are explained in the following table.

Table 2.3 Programming connector for the blank control head—pins and signals

Pinout	Pin	Signal name	Description
<p>front view</p>	1	RX AUD	Receive audio output (after volume control)
	2	TXD	Asynchronous serial port: transmit data
	3	MIC AUD	Microphone audio input
	4	RXD	Asynchronous serial port: receive data
	5	ON/OFF	Hardware power on/software power off input (active low)
	6	+13.8V	Unswitched 13.8V power supply
	7	PTT	PTT input
	8	AGND	Analogue ground
	9	DGND	Digital ground

2.12 RJ45 Control Head

The RJ45 control head on the TM8252 telemetry radio has one RJ45 socket installed and an cavity where another RJ45 can be installed. The control head also has a power on/off LED.



Important

When a connector is not in use, the RJ45 bung for the connector must be installed. This ensures that the control head is sealed against water, dust and other environmental hazards.

Figure 2.9 TM8252 telemetry radio



Pin allocations for the RJ45 control head

The pin allocations for the RJ45 programming connector are explained in the following table.

Table 2.4 Programming connector for the RJ45 control head—pins and signals

Pinout	Pin	Signal name	Description
 front view	1	RX AUD	Receive audio output (after volume control)
	2	+13.8V	Unswitched 13.8V power supply
	3	TXD	Asynchronous serial port: transmit data
	4	PTT	PTT input
	5	MIC AUD	Microphone audio input
	6	AGND	Analogue ground
	7	RXD	Asynchronous serial port: receive data
	8	ON/OFF	Hardware power on/software power off input (active low)

Tait General Software Licence Agreement

This legal document is an Agreement between you (the "Licensee") and Tait Electronics Limited ("Tait"). By using any of the Software or Firmware items prior-installed in the related Tait product, included on CD or downloaded from the Tait website, (hereinafter referred to as "the Software or Firmware") you agree to be bound by the terms of this Agreement. If you do not agree to the terms of this Agreement, do not install and use any of the Software or Firmware. If you install and use any of the Software or Firmware that will be deemed to be acceptance of the terms of this licence agreement.

The terms of this Agreement shall apply subject only to any express written terms of agreement to the contrary between Tait and the Licensee.

Licence

TAIT GRANTS TO YOU AS LICENSEE THE NON-EXCLUSIVE RIGHT TO USE THE SOFTWARE OR FIRMWARE ON A SINGLE MACHINE PROVIDED YOU MAY ONLY:

1. COPY THE SOFTWARE OR FIRMWARE INTO ANY MACHINE READABLE OR PRINTED FORM FOR BACKUP PURPOSES IN SUPPORT OF YOUR USE OF THE PROGRAM ON THE SINGLE MACHINE (CERTAIN PROGRAMS, HOWEVER, MAY INCLUDE MECHANISMS TO LIMIT OR INHIBIT COPYING, THEY ARE MARKED "COPY PROTECTED"), PROVIDED THE COPYRIGHT NOTICE MUST BE REPRODUCED AND INCLUDED ON ANY SUCH COPY OF THE SOFTWARE OR FIRMWARE;
AND / OR

2. MERGE IT INTO ANOTHER PROGRAM FOR YOUR USE ON THE SINGLE MACHINE (ANY PORTION OF ANY SOFTWARE OR FIRMWARE MERGED INTO ANOTHER PROGRAM WILL CONTINUE TO BE SUBJECT TO THE TERMS AND CONDITIONS OF THIS AGREEMENT).

THE LICENSEE MAY NOT DUPLICATE, MODIFY, REVERSE COMPILATE OR REVERSE ASSEMBLE ANY SOFTWARE OR FIRMWARE IN WHOLE OR PART.

Important Notice

THE SOFTWARE OR FIRMWARE MAY CONTAIN OPEN SOURCE SOFTWARE COMPONENTS ("OPEN SOURCE COMPONENTS"). OPEN SOURCE COMPONENTS ARE EXCLUDED FROM THE TERMS OF THIS AGREEMENT EXCEPT AS EXPRESSLY STATED IN THIS AGREEMENT AND ARE COVERED BY THE TERMS OF THEIR RESPECTIVE LICENCES WHICH MAY EXCLUDE OR LIMIT ANY WARRANTY FROM OR LIABILITY OF THE DEVELOPERS AND/OR COPYRIGHT HOLDERS OF THE OPEN SOURCE COMPONENT FOR THE PERFORMANCE OF THOSE OPEN SOURCE COMPONENTS. YOU AGREE TO BE BOUND BY THE TERMS AND CONDITIONS OF EACH SUCH LICENCE. FOR MORE INFORMATION SEE:

[HTTP://SUPPORT.TAITWORLD.COM/GO/OPENSOURCE](http://support.taitworld.com/go/opensource)

Title to Software

THIS AGREEMENT DOES NOT CONSTITUTE A CONTRACT OF SALE IN RELATION TO THE SOFTWARE OR FIRMWARE SUPPLIED TO THE LICENSEE. NOT WITHSTANDING THE LICENSEE MAY OWN THE MAGNETIC OR OTHER PHYSICAL MEDIA ON WHICH THE SOFTWARE OR FIRMWARE WAS ORIGINALLY SUPPLIED, OR HAS SUBSEQUENTLY BEEN RECORDED OR FIXED, IT IS A FUNDAMENTAL TERM OF THIS AGREEMENT THAT AT ALL TIMES TITLE AND OWNERSHIP OF THE SOFTWARE OR FIRMWARE, WHETHER ON THE ORIGINAL MEDIA OR OTHERWISE, SHALL REMAIN VESTED IN TAIT OR THIRD PARTIES WHO HAVE GRANTED LICENCES TO TAIT.

Term and Termination

THIS LICENCE SHALL BE EFFECTIVE UNTIL TERMINATED IN ACCORDANCE WITH THE PROVISIONS OF THIS AGREEMENT. THE LICENSEE MAY TERMINATE THIS LICENCE AT ANY TIME BY DESTROYING ALL COPIES OF THE SOFTWARE OR FIRMWARE AND ASSOCIATED WRITTEN MATERIALS. THIS LICENCE WILL BE TERMINATED AUTOMATICALLY AND WITHOUT NOTICE FROM TAIT IN THE EVENT THAT THE LICENSEE FAILS TO COMPLY WITH ANY TERM OR CONDITION OF THIS AGREEMENT. THE LICENSEE AGREES TO DESTROY ALL COPIES OF THE SOFTWARE OR FIRMWARE AND ASSOCIATED WRITTEN MATERIALS IN THE EVENT OF SUCH TERMINATION.

Limited Warranty

THE SOFTWARE OR FIRMWARE (INCLUDING OPEN SOURCE COMPONENTS) IS SUPPLIED BY TAIT AND ACCEPTED BY THE LICENSEE "AS IS" WITHOUT WARRANTY OF ANY KIND EITHER EXPRESSED OR IMPLIED, INCLUDING BUT NOT BEING LIMITED TO ANY IMPLIED WARRANTIES AS TO MERCHANTABILITY OR FITNESS FOR ANY PARTICULAR PURPOSE. THE LICENSEE ACKNOWLEDGES THAT THE SOFTWARE OR FIRMWARE (INCLUDING OPEN SOURCE COMPONENTS) IS USED BY IT IN BUSINESS AND ACCORDINGLY TO THE MAXIMUM EXTENT PERMITTED BY LAW NO TERMS OR WARRANTIES WHICH ARE IMPLIED BY LEGISLATION SHALL APPLY TO THIS AGREEMENT. TAIT DOES NOT WARRANT THAT THE FUNCTIONS CONTAINED IN THE SOFTWARE OR FIRMWARE (INCLUDING OPEN SOURCE COMPONENTS) WILL MEET THE LICENSEE'S REQUIREMENTS OR THAT THE OPERATION OF THE SOFTWARE OR FIRMWARE (INCLUDING OPEN SOURCE COMPONENTS) WILL BE UNINTERRUPTED OR ERROR FREE.

Exclusion of Liability

IN NO CIRCUMSTANCES SHALL TAIT BE UNDER ANY LIABILITY TO THE LICENSEE, OR ANY OTHER PERSON WHATSOEVER, WHETHER IN TORT (INCLUDING NEGLIGENCE), CONTRACT (EXCEPT AS EXPRESSLY PROVIDED IN THIS AGREEMENT), EQUITY, UNDER ANY STATUTE, OR OTHERWISE AT LAW FOR ANY LOSSES OR DAMAGES WHETHER GENERAL, SPECIAL, EXEMPLARY, PUNITIVE, DIRECT, INDIRECT OR CONSEQUENTIAL ARISING OUT OF OR IN CONNECTION WITH ANY USE OR INABILITY OF USING THE SOFTWARE OR FIRMWARE (INCLUDING OPEN SOURCE COMPONENTS).

THE LICENSEE'S SOLE REMEDY AGAINST TAIT WILL BE LIMITED TO BREACH OF CONTRACT AND TAIT'S SOLE AND TOTAL LIABILITY FOR ANY SUCH CLAIM SHALL BE LIMITED AT THE OPTION OF TAIT TO THE REPAIR OR REPLACEMENT OF THE SOFTWARE OR FIRMWARE OR THE REFUND OF THE PURCHASE PRICE OF THE SOFTWARE OR FIRMWARE.

General

THE LICENSEE CONFIRMS THAT IT SHALL COMPLY WITH THE PROVISIONS OF LAW IN RELATION TO THE SOFTWARE OR FIRMWARE.

Law and Jurisdiction

THIS AGREEMENT SHALL BE SUBJECT TO AND CONSTRUED IN ACCORDANCE WITH NEW ZEALAND LAW AND DISPUTES BETWEEN THE PARTIES CONCERNING THE PROVISIONS HEREOF SHALL BE DETERMINED BY THE NEW ZEALAND COURTS OF LAW. PROVIDED HOWEVER TAIT MAY AT ITS ELECTION BRING PROCEEDINGS FOR BREACH OF THE TERMS HEREOF OR FOR THE ENFORCEMENT OF ANY JUDGEMENT IN RELATION TO A BREACH OF THE TERMS HEREOF IN ANY JURISDICTION TAIT CONSIDERS FIT FOR THE PURPOSE OF ENSURING COMPLIANCE WITH THE TERMS HEREOF OR OBTAINING RELIEF FOR BREACH OF THE TERMS HEREOF.

No Dealings

THE LICENSEE MAY NOT SUBLICENSE, ASSIGN OR TRANSFER THE LICENCE OR THE PROGRAM EXCEPT AS EXPRESSLY PROVIDED IN THIS AGREEMENT. ANY ATTEMPT OTHERWISE TO SUBLICENSE, ASSIGN OR TRANSFER ANY OF THE RIGHTS, DUTIES OR OBLIGATIONS HEREUNDER IS VOID.

No Other Terms

THE LICENSEE ACKNOWLEDGES THAT IT HAS READ THIS AGREEMENT, UNDERSTANDS IT AND AGREES TO BE BOUND BY ITS TERMS AND CONDITIONS. THE LICENSEE FURTHER AGREES THAT SUBJECT ONLY TO ANY EXPRESS WRITTEN TERMS OF AGREEMENT TO THE CONTRARY BETWEEN TAIT AND THE LICENSEE THIS IS THE COMPLETE AND EXCLUSIVE STATEMENT OF THE AGREEMENT BETWEEN IT AND TAIT IN RELATION TO THE SOFTWARE OR FIRMWARE WHICH SUPERSEDES ANY PROPOSAL OR PRIOR AGREEMENT, ORAL OR WRITTEN AND ANY OTHER COMMUNICATIONS BETWEEN THE LICENSEE AND TAIT RELATING TO THE SOFTWARE OR FIRMWARE.

Notes

Notes

Cable Connections

Terminating the antenna cable

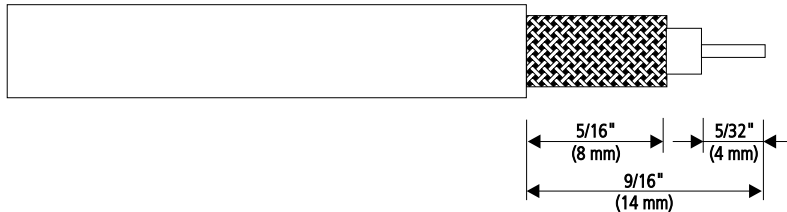

For more information, refer to [“Installing the Antenna”](#) on page 16.

Power and remote speaker connections

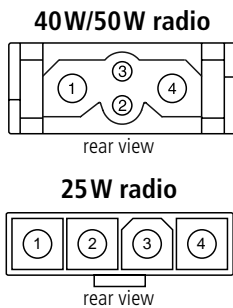

Pin	Signal	Function
1	AGND	Earth return
2	SPK-	External speaker -
3	SPK+	External speaker +
4	+13V8 BATT	DC power input (10.8V to 16.0V)

For more information, refer to [“Connecting the Power Cable to the Power Source”](#) and [“Connecting a Remote Speaker”](#) on page 17.

Ignition sense, emergency switch, and external alert device connections

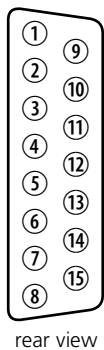

Pin	Signal	Function
4	AUX GPI3	Ignition sense
5	AUX GPI2	Emergency switch +
8	+13V8 SW	External alert device +
10	AUX GPIO4	External alert device -
15	AGND	Emergency switch -

For more information, refer to [“Connecting to the Auxiliary Connector \(Ignition Signal, Emergency Switch, External Alert Devices\)”](#) on page 19.

www.taitworld.com

MMA-00028-01



TM8100/TM8200 Installation Guide
© Tait Electronics Limited July 2005